



SY54016AR

Low Voltage 1.2V/1.8V CML Differential Line Driver/Receiver 3.2Gbps, 3.2GHz

General Description

The SY54016AR is a fully differential, low voltage 1.2V/1.8V CML Line Driver/Receiver. The SY54016AR can process clock signals as fast as 3.2GHz or data patterns up to 3.2Gbps.

The differential input includes Micrel's unique, 3-pin input termination architecture that interfaces to LVPECL, LVDS or CML differential signals, as small as 100mV (200mV_{pp}) without any level-shifting or termination resistor networks in the signal path. For AC-coupled input interface applications, an internal voltage reference is provided to bias the V_T pin. The outputs are CML, with extremely fast rise/fall times guaranteed to be less than 95ps.

The SY54016AR operates from a 2.5V ±5% core supply and a 1.8V or 1.2V ±5% output supply and is guaranteed over the full industrial temperature range (–40°C to +85°C). The SY54016AR is part of Micrel's high-speed, Precision Edge[®] product line.

Datasheets and support documentation can be found on Micrel's web site at: www.micrel.com.

Functional Block Diagram

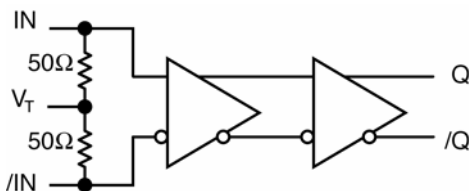

Precision Edge[®]

Features

- 1.2V/1.8V CML Differential Line Driver/Receiver
- Guaranteed AC performance over temperature and voltage:
 - DC-to- > 3.2Gbps throughput
 - <280ps propagation delay (IN-to-Q)
 - <95ps rise/fall times
- Ultra-low jitter design
 - <1ps_{RMS} cycle-to-cycle jitter
 - <10ps_{PP} total jitter
 - <1ps_{RMS} random jitter
 - <10ps_{PP} deterministic jitter
- High-speed CML outputs
- 2.5V ±5% , 1.8/1.2V ±5% power supply operation
- Industrial temperature range: –40°C to +85°C
- Available in 8-pin (2mm x 2mm) MLF[®] package

Applications

- Data Distribution: OC-48, OC-48+FEC
- SONET clock and data distribution
- Fibre Channel clock and data distribution
- Gigabit Ethernet clock and data distribution

Markets

- Storage
- ATE
- Test and measurement
- Enterprise networking equipment
- High-end servers
- Metro area network equipment

Precision Edge is a registered trademark of Micrel, Inc.
MLF and MicroLeadFrame are registered trademarks of Amkor Technology.

Micrel Inc. • 2180 Fortune Drive • San Jose, CA 95131 • USA • tel +1 (408) 944-0800 • fax + 1 (408) 474-1000 • <http://www.micrel.com>

Ordering Information⁽¹⁾

Part Number	Package Type	Operating Range	Package Marking	Lead Finish
SY54016ARMGTR ⁽²⁾	MLF-8	Industrial	8AR with Pb-Free bar-line indicator	NiPdAu Pb-Free

Notes:

- Contact factory for die availability. Dice are guaranteed at $T_A = 25^\circ\text{C}$, DC Electricals only.
- Tape and Reel.

Pin Configuration

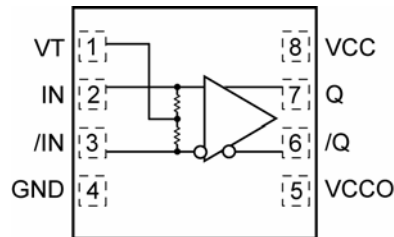

8-Pin MLF[®] (MLF-16)

Pin Description

Pin Number	Pin Name	Pin Function
2,3	IN, /IN	Differential Input: This input pair is the differential signal input to the device. Input accepts differential signals as small as 100mV (200mV _{PP}). Each input pin internally terminates with 50Ω to the VT pin.
1	VT	Input Termination Center-Tap: Each side of the differential input pair terminates to VT pin. This pin provides a center-tap to a termination network for maximum interface flexibility. An internal high impedance resistor divider biases VT to allow input AC-coupling. For AC-coupling, bypass VT with a 0.1μF low ESR capacitor to VCC. See "Interface Applications" subsection and Figure 2a.
8	VCC	Positive Power Supply: Bypass with 0.1μF//0.01μF low ESR capacitors as close to the V _{CC} pin as possible. Supplies input and core circuitry.
5	VCCO	Output Supply: Bypass with 0.1μF//0.01μF low ESR capacitors as close to the V _{CCO} pin as possible. Supplies the output buffer.
4	GND, Exposed pad	Ground: Exposed pad must be connected to a ground plane that is the same potential as the ground pin.
7,6	Q, /Q	CML Differential Output Pair: Differential buffered copy of the input signal. The output swing is typically 390mV. See "Interface Applications" subsection for termination information.

Absolute Maximum Ratings⁽¹⁾

Supply Voltage (V_{CC}) -0.5V to +3.0V
 Supply Voltage (V_{CCO}) -0.5V to +2.7V
 $V_{CC} - V_{CCO}$ <1.8V
 $V_{CCO} - V_{CC}$ <0.5V
 Input Voltage (V_{IN}) -0.5V to V_{CC}
 CML Output Voltage (V_{OUT}) 0.6V to $V_{CCO}+0.5V$
 Current (I_T)
 Source or sink current on VT pin $\pm 100mA$
 Input Current
 Source or sink current on (IN, /IN) $\pm 50mA$
 Maximum operating Junction Temperature 125°C
 Lead Temperature (soldering, 20sec.) 260°C
 Storage Temperature (T_s) -65°C to +150°C

Operating Ratings⁽²⁾

Supply Voltage (V_{CC}) 2.375V to 2.625V
 (V_{CCO}) 1.14V to 1.9V
 Ambient Temperature (T_A) -40°C to +85°C
 Package Thermal Resistance⁽³⁾
 MLF[®]
 Still-air (θ_{JA}) 93 °C/W
 Junction-to-board (ψ_{JB}) 56 °C/W

DC Electrical Characteristics⁽⁴⁾

$T_A = -40^\circ C$ to $+85^\circ C$, unless otherwise stated.

Symbol	Parameter	Condition	Min	Typ	Max	Units
V_{CC}	Power Supply Voltage Range	V_{CC}	2.375	2.5	2.625	V
		V_{CCO}	1.14	1.2	1.26	V
		V_{CCO}	1.7	1.8	1.9	V
I_{CC}	Power Supply Current	Max. V_{CC}		11	16	mA
I_{CCO}	Power Supply Current	No Load. Max. V_{CCO}		16	21	mA
R_{IN}	Input Resistance (IN-to- V_T , /IN-to- V_T)		45	50	55	Ω
R_{DIFF_IN}	Differential Input Resistance (IN-to-/IN)		90	100	110	Ω
V_{IH}	Input HIGH Voltage (IN, /IN)	IN, /IN	1.2		V_{CC}	V
V_{IL}	Input LOW Voltage (IN, /IN)	V_{IL} with $V_{IH} = 1.2V$	0.2		$V_{IH}-0.1$	V
V_{IH}	Input HIGH Voltage (IN, /IN)	IN, /IN	1.14		V_{CC}	V
V_{IL}	Input LOW Voltage (IN, /IN)	V_{IL} with $V_{IH} = 1.14V, (1.2V-5\%)$	0.66		$V_{IH}-0.1$	V
V_{IN}	Input Voltage Swing (IN, /IN)	see Figure 3a	0.1		1.0	V
V_{DIFF_IN}	Differential Input Voltage Swing (IN - /IN)	see Figure 3b	0.2		2.0	V
V_{T_IN}	Voltage from Input to V_T				1.28	V

Notes:

1. Permanent device damage may occur if absolute maximum ratings are exceeded. This is a stress rating only and functional operation is not implied at conditions other than those detailed in the operational sections of this data sheet. Exposure to absolute maximum ratings conditions for extended periods may affect device reliability.
2. The data sheet limits are not guaranteed if the device is operated beyond the operating ratings.
3. Package thermal resistance assumes exposed pad is soldered (or equivalent) to the device's most negative potential on the PCB. ψ_{JB} and θ_{JA} values are determined for a 4-layer board in still-air number, unless otherwise stated.
4. The circuit is designed to meet the DC specifications shown in the above table after thermal equilibrium has been established.

CML Outputs DC Electrical Characteristics⁽⁵⁾

$V_{CCO} = 1.14V$ to $1.26V$ $R_L = 50\Omega$ to V_{CCO} ,

$V_{CCO} = 1.7V$ to $1.9V$, $R_L = 50\Omega$ to V_{CCO} or 100Ω across the outputs,

$V_{CC} = 2.375V$ to $2.625V$. $T_A = -40^\circ C$ to $+85^\circ C$, unless otherwise stated.

Symbol	Parameter	Condition	Min	Typ	Max	Units
V_{OH}	Output HIGH Voltage	$R_L = 50\Omega$ to V_{CCO}	$V_{CCO}-0.020$	$V_{CCO}-0.010$	V_{CCO}	V
V_{OUT}	Output Voltage Swing	See Figure 3a	300	390	475	mV
V_{DIFF_OUT}	Differential Output Voltage Swing	See Figure 3b	600	780	950	mV
R_{OUT}	Output Source Impedance		45	50	55	Ω

Note:

5. The circuit is designed to meet the DC specifications shown in the above table after thermal equilibrium has been established.

AC Electrical Characteristics

$V_{CCO} = 1.14V$ to $1.26V$ $R_L = 50\Omega$ to V_{CCO} ,

$V_{CCO} = 1.7V$ to $1.9V$, $R_L = 50\Omega$ to V_{CCO} or 100Ω across the outputs,

$V_{CC} = 2.375V$ to $2.625V$. $T_A = -40^\circ C$ to $+85^\circ C$, unless otherwise stated.

Symbol	Parameter	Condition	Min	Typ	Max	Units
f_{MAX}	Maximum Frequency	NRZ Data	3.2			Gbps
		$V_{OUT} > 200mV$ Clock	3.2			GHz
t_{PD}	Propagation Delay IN-to-Q	Figure 1a	130	190	280	ps
t_{Skew}	Part-to-Part Skew	Note 6			75	ps
t_{Jitter}	Data Random Jitter	Note 7			1	ps _{RMS}
	Deterministic Jitter	Note 8			10	ps _{PP}
	Clock Cycle-to-Cycle Jitter	Note 9			1	ps _{RMS}
	Total Jitter	Note 10			10	ps _{PP}
t_R t_F	Output Rise/Fall Times (20% to 80%)	At full output swing.	30	60	95	ps
	Duty Cycle	Differential I/O	47		53	%

Notes:

- Part-to-part skew is defined for two parts with identical power supply voltages at the same temperature and no skew at the edges at the respective inputs.
- Random jitter is measured with a K28.7 pattern, measured at $\leq f_{MAX}$.
- Deterministic jitter is measured at 2.5Gbps with both K28.5 and $2^{23}-1$ PRBS pattern.
- Cycle-to-cycle jitter definition: the variation period between adjacent cycles over a random sample of adjacent cycle pairs. $t_{JITTER_CC} = T_n - T_{n+1}$, where T is the time between rising edges of the output signal.
- Total jitter definition: with an ideal clock input frequency of $\leq f_{MAX}$ (device), no more than one output edge in 10^{12} output edges will deviate by more than the specified peak-to-peak jitter value.

Interface Applications

For Input Interface Applications see Figures 4a-f and for CML Output Termination see Figures 5a-d.

CML Output Termination with VCCO 1.2V

For VCCO of 1.2V, Figure 5a, terminate the output with 50Ω-to-1.2V, DC-coupled, not 100Ω differentially across the outputs.

If AC-coupling is used, Figure 5d, terminate into 50Ω-to-1.2V before the coupling capacitor and then connect to a high value resistor to a reference voltage.

Do not AC-couple with internally terminated receiver. For example, 50Ω ANY-IN input. AC-coupling will offset the output voltage by 200mV and this offset voltage will be too low for proper driver operation.

CML Output Termination with VCCO 1.8V

For VCCO of 1.8V, Figure 5a and Figure b, terminate with either 50Ω-to-1.8V or 100Ω differentially across the outputs. AC- or DC-coupling is fine.

Input AC Coupling

The SY54016AR input can accept AC coupling from any driver. Bypass VT with a 0.1μF low ESR capacitor to VCC as shown in Figures 4c and 4d. VT has an internal high impedance resistor divider as shown in Figure 2a, to provide a bias voltage for AC-coupling.

Timing Diagrams

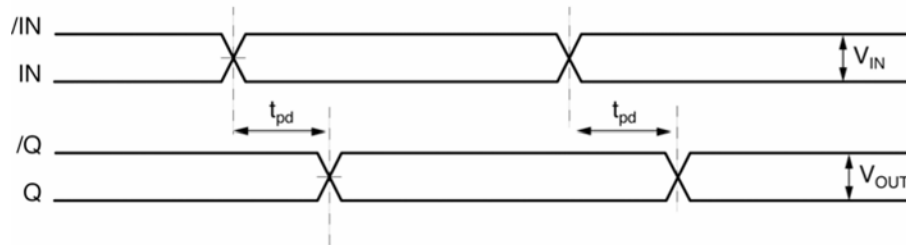
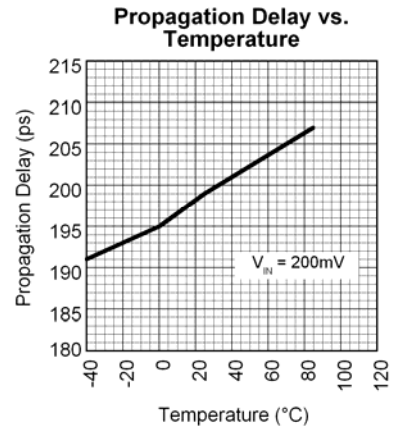
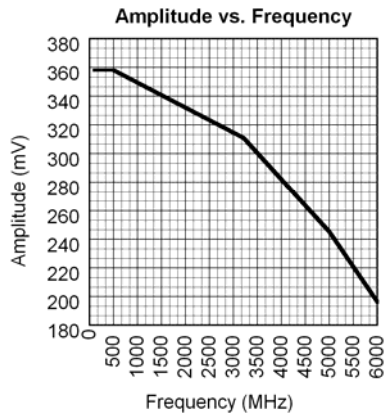

Figure 1a. Propagation Delay

Typical Characteristics

$V_{CC} = 2.5V$, $V_{CC0} = 1.2V$, $GND = 0V$, $R_L = 50\Omega$ to $1.2V$, $V_{IN} = 100mV$, $T_A = 25^\circ C$, unless otherwise stated.



Functional Characteristics

$V_{CC} = 2.5V$, $GND = 0V$, $V_{IN} = 400mV$, $R_L = 50\Omega$ to V_{CCO} , Data Pattern: $2^{23}-1$, $T_A = 25^\circ C$, unless otherwise stated.

Output Eyes with $V_{CCO} = 1.2V$

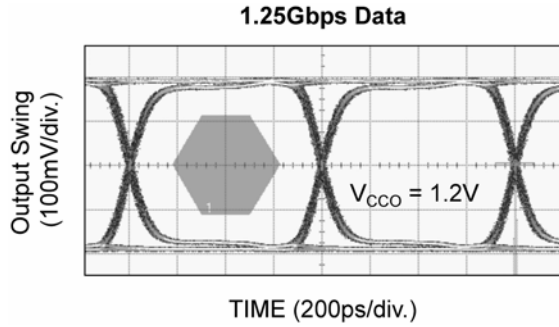

Output Eyes with $V_{CCO} = 1.8V$

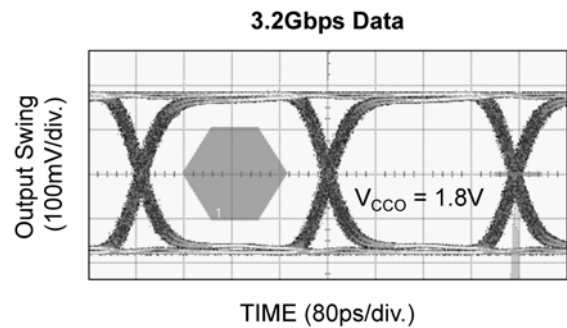
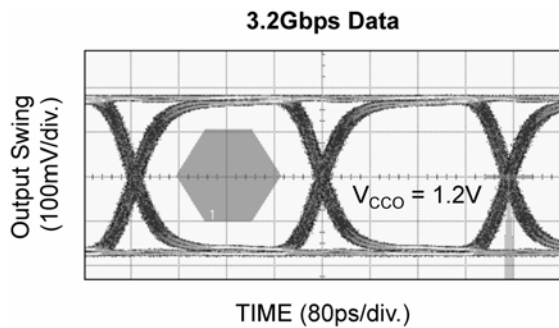
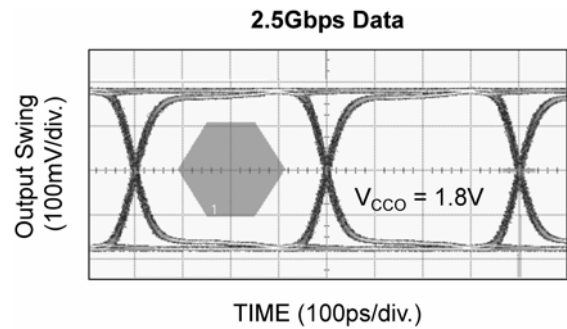
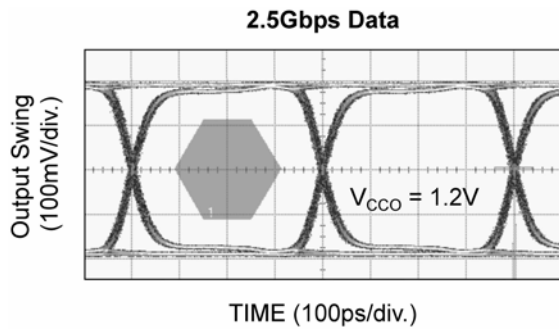
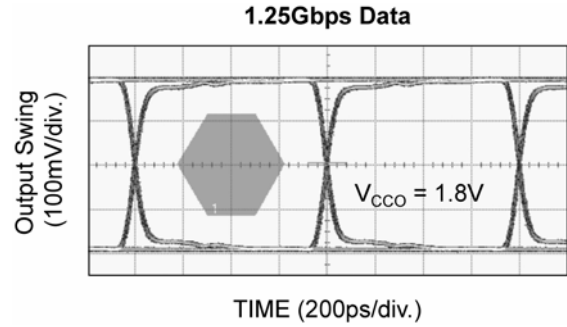

Functional Characteristics

$V_{CC} = 2.5V$, $GND = 0V$, $V_{IN} = 400mV$, $R_L = 50\Omega$ to V_{CCO} , $T_A = 25^\circ C$, unless otherwise stated.

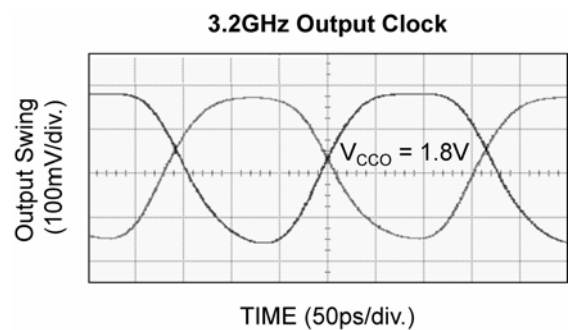
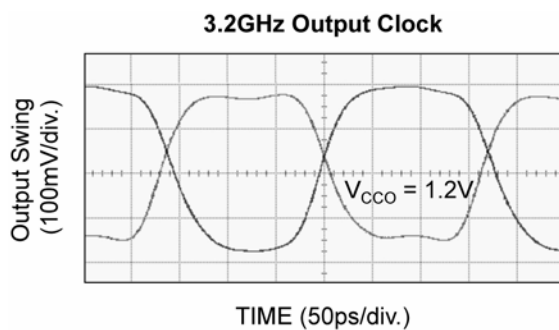
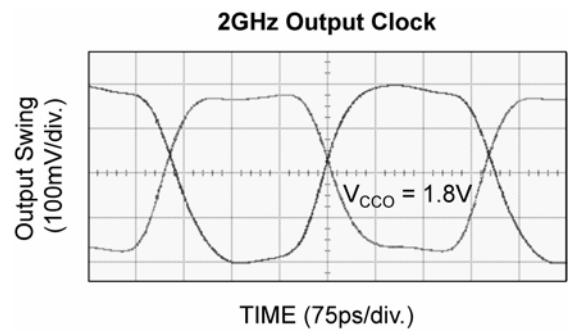
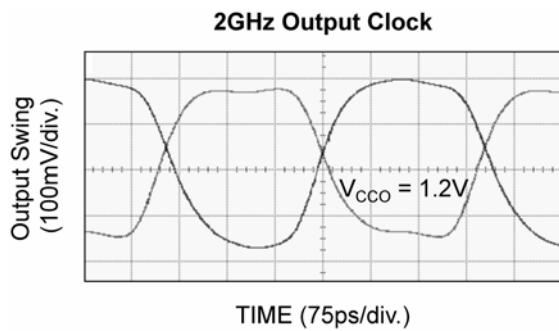
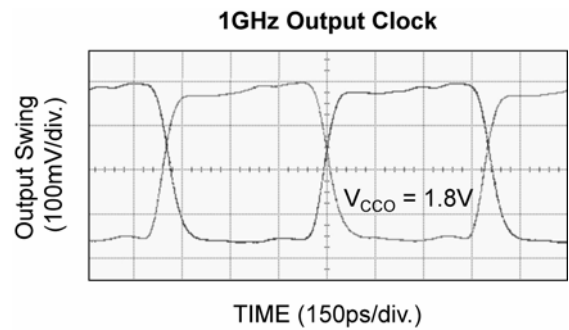
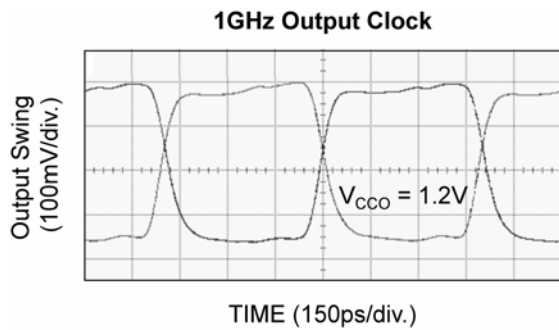
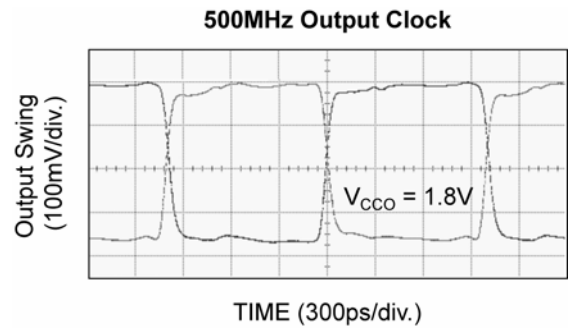
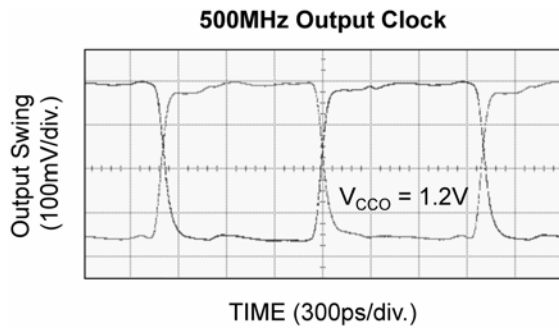

Input and Output Stage

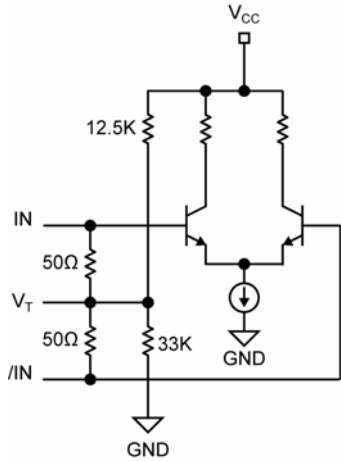

Figure 2a. Simplified Differential Input Buffer

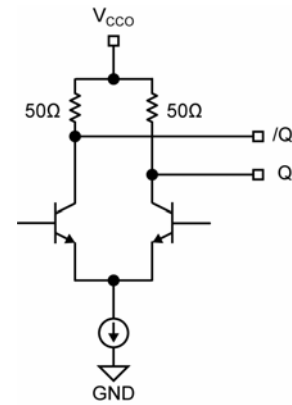

Figure 2b. Simplified CML Output Buffer

Single-Ended and Differential Swings



Figure 3a. Single-Ended Swing

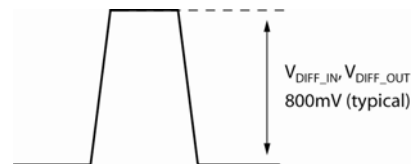

Figure 3b. Differential Swing

Input Interface Applications

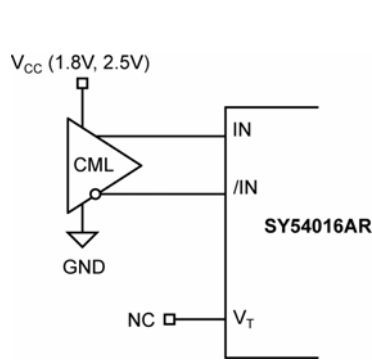

Figure 4a. CML Interface (DC-Coupled, 1.8V, 2.5V)

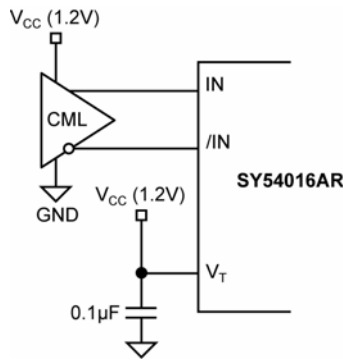

Figure 4b. CML Interface (DC-Coupled, 1.2V)

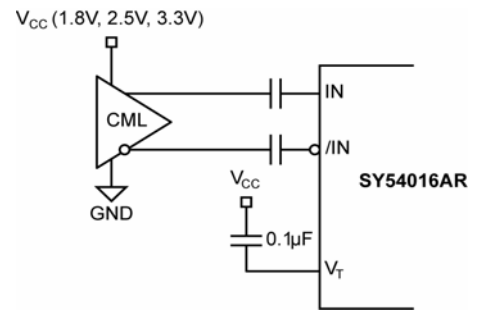

Figure 4c. CML Interface (AC-Coupled)

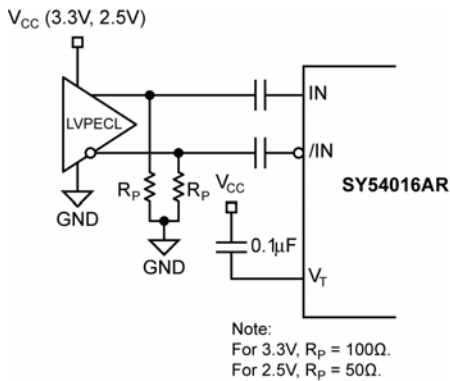

Figure 4d. LVPECL Interface (AC-Coupled)

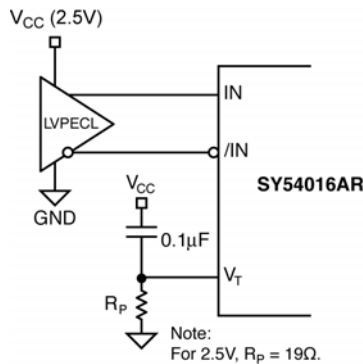

Figure 4e. LVPECL Interface (DC-Coupled)

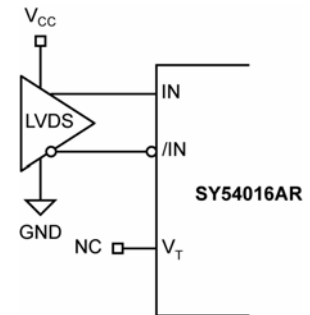

Figure 4f. LVDS Interface

CML Output Termination

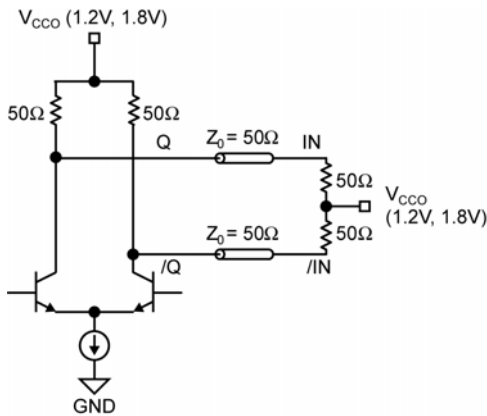

Figure 5a. 1.2V or 1.8V CML DC-Coupled Termination

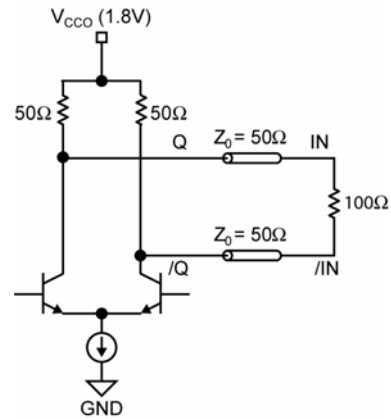

Figure 5b. 1.8V DC-Coupled Termination

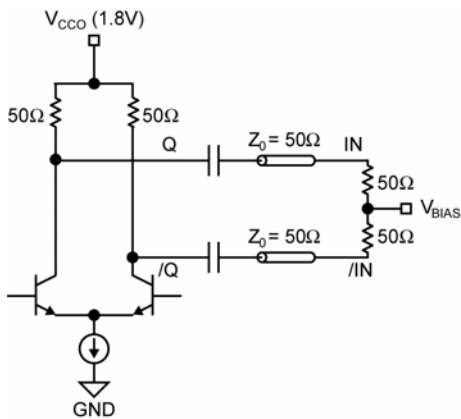

Figure 5c. CML AC-Coupled Termination (VCCO 1.8V Only)

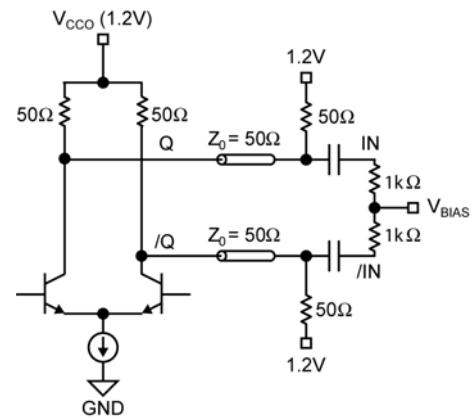
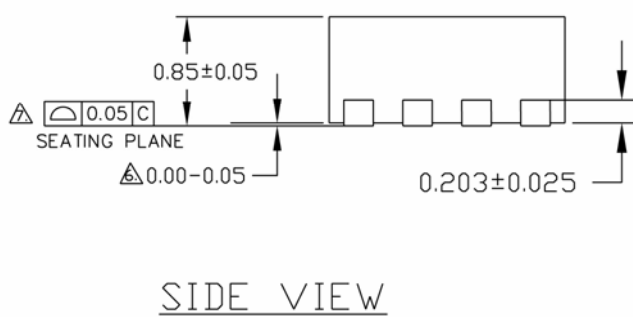
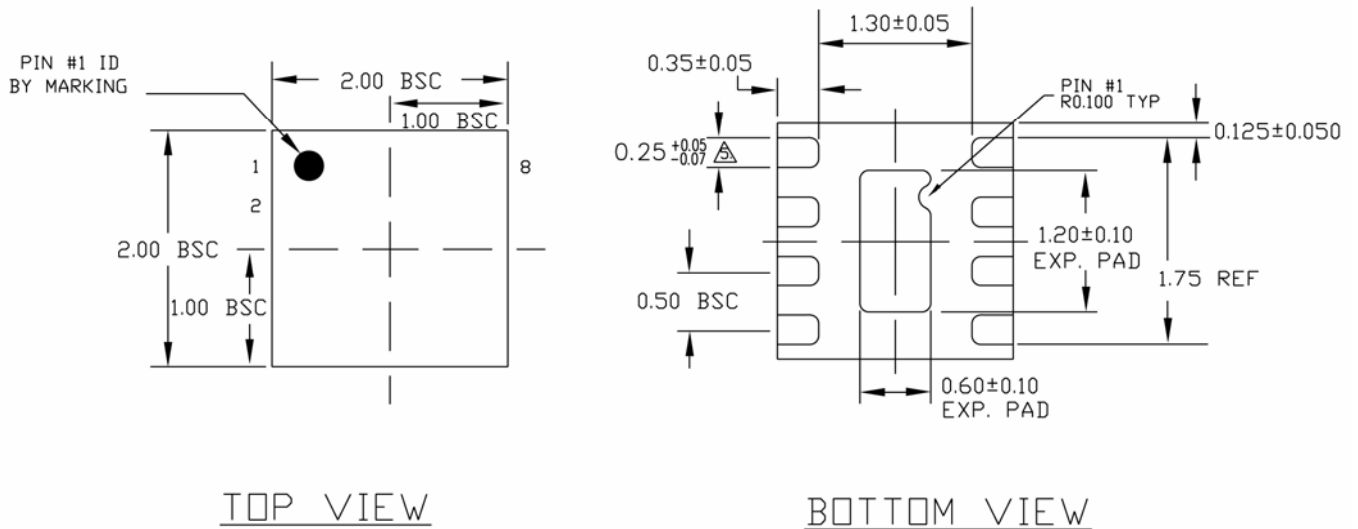

Figure 5d. CML AC-Coupled Termination (VCCO 1.2V Only)

Related Product and Support Documents

Part Number	Function	Datasheet Link
SY54016R	3.2Gbps Precision, 1:1 Low Voltage CML Buffer with Internal Termination and Fail Safe Input	http://www.micrel.com/page.do?page=/product-info/products/sy54016r.shtml
HBW Solutions	New Products and Termination Application Notes	http://www.micrel.com/page.do?page=/product-info/as/HBWsolutions.shtml

Package Information



- NOTE:
1. ALL DIMENSIONS ARE IN MILLIMETERS.
 2. MAX. PACKAGE WARPAGE IS 0.05 mm.
 3. MAXIMUM ALLOWABLE BURRS IS 0.076 mm IN ALL DIRECTIONS.
 4. PIN #1 ID ON TOP WILL BE LASER/INK MARKED.
- △ DIMENSION APPLIES TO METALIZED TERMINAL AND IS MEASURED BETWEEN 0.20 AND 0.25 mm FROM TERMINAL TIP.
- △ APPLIED ONLY FOR TERMINALS.
- △ APPLIED FOR EXPOSED PAD AND TERMINALS.

8-Pin MLF® (2mm x 2mm) (MLF-8)

MICREL, INC. 2180 FORTUNE DRIVE SAN JOSE, CA 95131 USA
 TEL +1 (408) 944-0800 FAX +1 (408) 474-1000 WEB <http://www.micrel.com>

The information furnished by Micrel in this data sheet is believed to be accurate and reliable. However, no responsibility is assumed by Micrel for its use. Micrel reserves the right to change circuitry and specifications at any time without notification to the customer.

Micrel Products are not designed or authorized for use as components in life support appliances, devices or systems where malfunction of a product can reasonably be expected to result in personal injury. Life support devices or systems are devices or systems that (a) are intended for surgical implant into the body or (b) support or sustain life, and whose failure to perform can be reasonably expected to result in a significant injury to the user. A Purchaser's use or sale of Micrel Products for use in life support appliances, devices or systems is a Purchaser's own risk and Purchaser agrees to fully indemnify Micrel for any damages resulting from such use or sale.

© 2008 Micrel, Incorporated.